



Atlas Copco



Gamme complète de solutions submersibles d'assèchement

La gamme WEDA (50 Hz)

Pompes WEDA pour l'assèchement

Les pompes électriques submersibles et accessoires WEDA sont conçus pour un large éventail d'applications d'assèchement dans de multiples secteurs. Elles vous fournissent la performance, la fiabilité et la facilité d'utilisation dont vous avez besoin. Les pompes WEDA sont équipées d'un démarreur intégré, d'un système de protection moteur ainsi que d'un dispositif de contrôle de niveau disponible en option. Des diffuseurs en caoutchouc réglables et résistants à l'usure ainsi que des roues en fonte au chrome garantissent une utilisation durable, même dans les environnements les plus difficiles.

Chez Atlas Copco, nous connaissons les pompes, leurs utilisations et, plus important encore, les personnes qui les utilisent. Nous proposons une gamme complète de pompes électriques submersibles haut de gamme et légères spécialement conçues pour les applications de drainage ainsi que le pompage de la vase et de la boue, disponibles pour différentes tensions.















Les pompes WEDA sont conçues pour durer. Leur système d'étanchéité unique et leur conception modulaire leur permettent de faire partie des pompes les plus flexibles du marché. Faciles à utiliser et à entretenir, les pompes WEDA fournissent une performance optimale. Le système d'étanchéité WEDA est la solution de maintenance par excellence, l'installation pouvant se faire facilement sur le site.



Il y a toujours une pompe WEDA pour chaque application d'assèchement

Nous comprenons les besoins d'assèchement de nos clients. Ces derniers varient en fonction du site et de l'application. C'est pourquoi nous proposons une gamme immergée conçue pour le drainage (D), la boue (S) et le dragage (L).

Ces applications requièrent en effet des pompes spécialement développées pour traiter des produits corrosifs et abrasifs, ainsi que les solides qu'ils contiennent.

| Pompes de drainage (WEDA D) | Pompes à boues (WEDA S) | Pompes de dragage (WEDA L) |
|---|---|---|
|  |  |  |
| DENSITÉ →  → DE L'EAU JUSQU'À 1 100 kg/m ³ | DENSITÉ →  → DE L'EAU JUSQU'À 1 400 kg/m ³ | DENSITÉ →  → DE L'EAU JUSQU'À 1 700 kg/m ³ |
|  CONCEPTION ÉVACUATION PAR LE HAUT |  CONCEPTION ÉVACUATION PAR LE BAS |  CONCEPTION ÉVACUATION PAR LE BAS ET PAR LE HAUT |
|  GRANULOMÉTRIE 4-12 mm |  GRANULOMÉTRIE 25-50 mm |  GRANULOMÉTRIE 20-60 mm |
|  pH DE 5 À 8 |  pH DE 5 À 8 |  pH DE 2 À 10 |

Applications

- Assèchement général
- Eaux souterraines
- Eau brute
- Sites de construction
- Eau contenant de la boue
- Vase ou boue légère
- Nettoyage de réservoir
- Nettoyage de tranchées et bassins
- Exploitation minière
- Liquides abrasifs contenant de nombreux solides
- Carrières
- Dragage
- Bassins de décantation

Gamme WEDA S

Les pompes à boues WEDA sont capables de traiter de la boue épaisse, meuble et humide ou d'autres mélanges visqueux similaires liquides ou contenant des solides, en particulier les produits issus des processus industriels ou de raffinage.

ÉTANCHÉITÉ DE CÂBLE AMÉLIORÉE

Permet de prévenir toute fuite d'eau au niveau de l'entrée du câble

FONCTIONNEMENT À SEC

Une conception améliorée des nervures permet de garantir le refroidissement externe du moteur pendant une durée d'utilisation accrue

PROTECTION DU MOTEUR

Moteurs de classe F, avec thermorégulateurs dans chaque enroulement

GRANULOMÉTRIE AMÉLIORÉE

Les pompes à boues peuvent traiter des solides jusqu'à 50 mm

 GRANULOMÉTRIE
25-50 mm

CONCEPTION ROBUSTE

La base de la pompe garantit sa stabilité tout en permettant le passage de solides de taille importante

WEDA+

1. Contrôle du sens de rotation
2. Protection contre la défaillance de phase
3. Thermorégulateurs
4. Inverseur de phase sur prise pour les pompes triphasées



INSPECTION AISÉE

Bouchon de contrôle de l'huile externe pour une inspection rapide de l'huile

SOLUTION D'ÉTANCHÉITÉ MODULAIRE

Le système d'étanchéité est adapté en fonction de la taille de la pompe afin d'offrir la meilleure solution possible

PERFORMANCE DURABLE

Des en fonte au chrome (55 HRC) offrent une meilleure résistance à l'usure

55  **HRC**



Atlas Copco



Des pompes résistantes pour des environnements difficiles

La construction en alliage d'aluminium unique des pompes WEDA offre une résistance supérieure à la corrosion dans un large éventail d'applications.

Gamme WEDA S

Caractéristiques techniques



| | | WEDA S04N | WEDA S08N | WEDA S30N | | WEDA S60N |
|-------------------------------|-------------------|-----------|-----------|-----------|-----|-----------|
| Spécifications | | 1ph | 1ph | 1ph | 3ph | 3ph |
| Hauteur de refoulement max. | m | 10,5 | 13,0 | 12,5 | 15 | 25 |
| Débit max. | l/min | 270 | 317 | 700 | 900 | 1750 |
| | m ³ /h | 16,2 | 19,0 | 42 | 54 | 105 |
| Puissance nominale | kW | 0,40 | 0,75 | 1,8 | 2,5 | 6,9 |
| Puissance d'alimentation max. | kW | 0,65 | 1,2 | 2,2 | 3,1 | 8,0 |
| Refoulement | in | 2" | 2" | 3" | 3" | 3" (4") |
| Granulométrie max. | mm | 25 | 25 | 50 | 50 | 50 |
| Poids et dimensions | | | | | | |
| Poids | kg | 10 | 13 | 25 | 25 | 65 |
| Hauteur | mm | 375 | 416 | 620 | 620 | 870 |
| Largeur | mm | 277 | 277 | 326 | 326 | 450 |
| Diamètre | mm | 241 | 241 | 250 | 250 | 350 |

Applications typiques

- Eau contenant de la boue
- Vase ou boue légère
- Nettoyage de réservoir
- Nettoyage de tranchées et bassins
- Exploitation minière

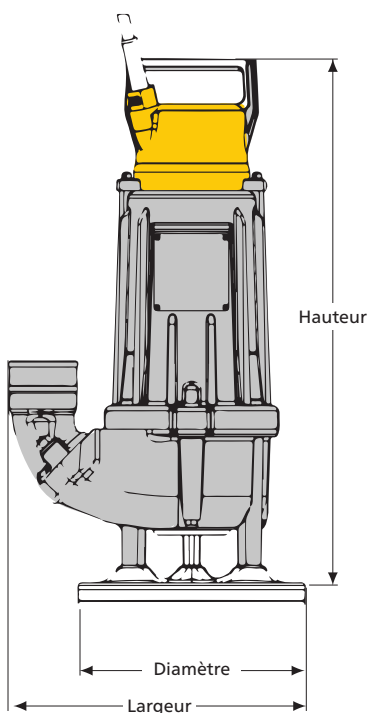

Courbes de performance

 **WEDA S04N**

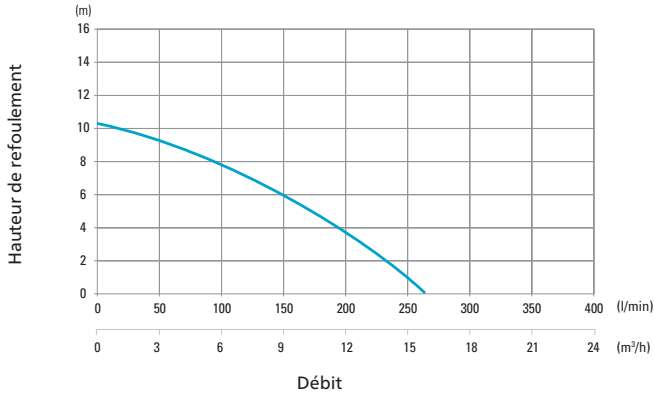

 **WEDA S08N**

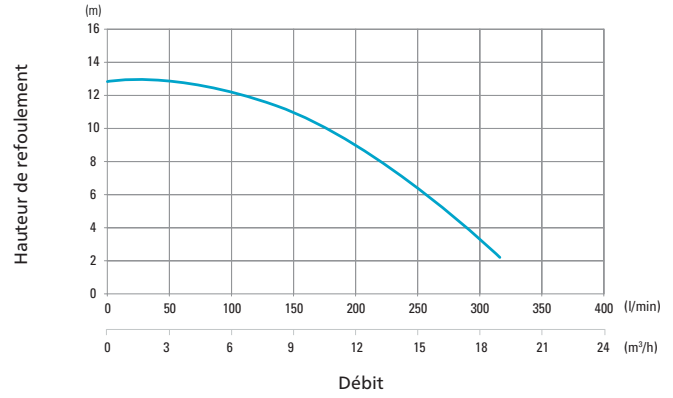

 **WEDA S30N**

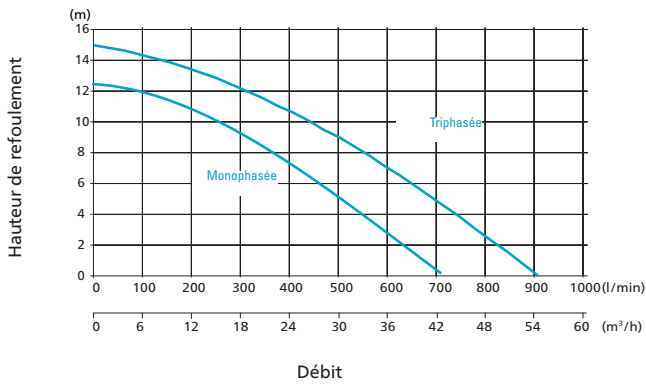

 **WEDA S60N**

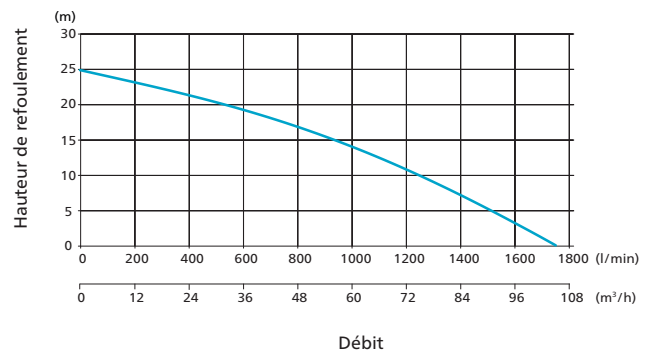

— Moyenne pression

Accessoires

Refoulements

Nous savons que vous avez des raccords préférentiels. C'est pourquoi nous vous proposons quatre types différents. Tous peuvent être montés en position verticale ou horizontale.

• Flexible



• Storz



• ISO-G



• NPT



Régulateurs de niveau

Pour un contrôle facile du niveau d'eau grâce à la mise en marche/l'arrêt automatique de la pompe :

• Flotteur



Anodes en zinc

Spécifiquement requises pour procéder au pompage de l'eau contenant une forte concentration de sels, telle que l'eau de mer, la saumure, etc.



Jupe d'aspiration basse

Pour drainer facilement l'eau jusqu'au niveau du sol.

Flexibles

Différents types de flexibles dotés de différents raccords sont disponibles de stock en différentes longueurs.

Revêtement époxy

Pour une protection supplémentaire contre la corrosion.

Kits d'entretien

Kit de joints

Le kit de joints se compose d'une sélection de composants haut de gamme pour le remplacement des garnitures mécaniques, afin de garantir un fonctionnement sans accroc après une opération de maintenance.

- Kit de joints toriques
- Garniture mécanique



ISP

L'ISP est un système d'étanchéité préassemblé, testé et prêt à l'utilisation contenant les garnitures mécaniques, les paliers, les joints et l'huile afin de garantir un fonctionnement sans accroc. Il s'agit d'une option de réparation sur site rapide et facile à installer, ce qui permet de réduire les coûts liés aux temps d'immobilisation de la machine.



Kit de pièces d'usure

Le kit de pièces d'usure se compose d'une sélection de composants permettant de rétablir les performances d'usine de la pompe. La solution idéale pour une révision ou un reconditionnement de la machine.

- Roue
- Plaque d'usure
- Écrou de roue

The Atlas Copco logo is positioned in the top right corner of the image. It consists of the brand name "Atlas Copco" in a blue, serif font, centered between two horizontal blue bars. The background of the entire image is a photograph of a large industrial machine, likely a tunnel boring machine (TBM) cutterhead, being lowered into a deep shaft. The machine is yellow and blue, with a large, perforated metal drum at the bottom. The shaft is made of concrete and has a large opening. In the background, there are trees and a clear blue sky. The overall scene is industrial and technical.A technical drawing of a circular component, likely a part of a TBM cutterhead, is overlaid on the bottom left of the image. The drawing shows a cross-section of the component with various dimensions and labels. The dimensions include 1720 (68.1), 1380 (54.3), 1370 (53.9), 1300 (51.2), 1200 (47.2), 1000 (39.4), 800 (31.5), 600 (23.6), 400 (15.7), 200 (7.9), 100 (3.9), 50 (1.9), 25 (0.9), 12.5 (0.5), 6.25 (0.25), 3.125 (0.125), 1.5625 (0.0625), 0.78125 (0.03125), 0.390625 (0.015625), 0.1953125 (0.0078125), 0.09765625 (0.00390625), 0.048828125 (0.001953125), 0.0244140625 (0.0009765625), 0.01220703125 (0.00048828125), 0.006103515625 (0.000244140625), 0.0030517578125 (0.0001220703125), 0.00152587890625 (0.00006103515625), 0.000762939453125 (0.000030517578125), 0.0003814697265625 (0.0000152587890625), 0.00019073486328125 (0.00000762939453125), 0.000095367431640625 (0.000003814697265625), 0.0000476837158203125 (0.0000019073486328125), 0.00002384185791015625 (0.00000095367431640625), 0.000011920928955078125 (0.000000476837158203125), 0.0000059604644775390625 (0.0000002384185791015625), 0.00000298023223876953125 (0.00000011920928955078125), 0.000001490116119384765625 (0.000000059604644775390625), 0.0000007450580596923828125 (0.0000000298023223876953125), 0.00000037252902984619140625 (0.00000001490116119384765625), 0.000000186264514923095703125 (0.000000007450580596923828125), 0.0000000931322574615478515625 (0.0000000037252902984619140625), 0.00000004656612873077392578125 (0.00000000186264514923095703125), 0.000000023283064365386962890625 (0.000000000931322574615478515625), 0.0000000116415321826934814453125 (0.0000000004656612873077392578125), 0.00000000582076609134674072265625 (0.00000000023283064365386962890625), 0.000000002910383045673370361328125 (0.000000000116415321826934814453125), 0.0000000014551915228366851806640625 (0.00000000005820766091346740361328125), 0.00000000072759576141834259033203125 (0.00000000002910383045673370361328125), 0.000000000363797880709171295166015625 (0.000000000014551915228366851806640625), 0.0000000001818989403545856475830078125 (0.0000000000072759576141834259033203125), 0.00000000009094947017729282379150390625 (0.00000000000363797880709171295166015625), 0.000000000045474735088646411895751953125 (0.000000000001818989403545856475830078125), 0.0000000000227373675443232059478759765625 (0.0000000000009094947017729282379150390625), 0.00000000001136868377216160297393798828125 (0.00000000000045474735088646411895751953125), 0.000000000005684341886080301486968994140625 (0.000000000000227373675443232059478759765625), 0.00000000000284217094304015074348449707265625 (0.0000000000001136868377216160297393798828125), 0.00000000000142108547152007537174224883678125 (0.00000000000005684341886080301486968994140625), 0.00000000000071054273576003768587112441840625 (0.0000000000000284217094304015074348449707265625), 0.000000000000355271367880018842935562209203125 (0.0000000000000142108547152003768587112441840625), 0.00000000000017763568394000942146778110460625 (0.00000000000000710542735760018842935562209203125), 0.000000000000088817841970004710733890552303125 (0.0000000000000035527136788000942146778110460625), 0.0000000000000444089209850023553669452761515625 (0.00000000000000177635683940004710733890552303125), 0.00000000000002220446049250117768347263807578125 (0.000000000000000888178419700023553669452761515625), 0.0000000000000111022302462505888417363190379140625 (0.0000000000000004440892098500117768347263807578125), 0.000000000000005551115123125294420868159547578125 (0.000000000000000222044604925005888417363190379140625), 0.00000000000000277555756156264721043407977390625 (0.00000000000000011102230246250294420868159547578125), 0.000000000000001387778780781323605217039886953125 (0.0000000000000000555111512312514721043407977390625), 0.0000000000000006938893903906618026085199434765625 (0.0000000000000000277555756156264721043407977390625), 0.00000000000000034694469519533090130425997173828125 (0.00000000000000001387778780781323605217039886953125), 0.0000000000000001734723475976654506521299858690625 (0.0000000000000000069388939039066180260851997173828125), 0.00000000000000008673617379883272532606499779140625 (0.000000000000000003469446951953309013042599858690625), 0.0000000000000000433680868994163626630324988957265625 (0.000000000000000001734723475976654506521299858690625), 0.0000000000000000216840434497081813315162494478828125 (0.0000000000000000008673617379883272532606499779140625), 0.00000000000000001084202172485409066575812472394140625 (0.000000000000000000433680868994163626630324988957265625), 0.0000000000000000054210108624270453328790623619707265625 (0.000000000000000000216840434497081813315162494478828125), 0.0000000000000000027105054312135226664395311809853125 (0.0000000000000000001084202172485409066575812472394140625), 0.00000000000000000135525271560676133322197559049265625 (0.000000000000000000054210108624270453328790623619707265625), 0.000000000000000000677626357803380666611097795246328125 (0.000000000000000000027105054312135226664395311809853125), 0.0000000000000000003388131789016903333055488976231640625 (0.0000000000000000000135525271560676133322197795246328125), 0.00000000000000000016940658945084516665277444881158203125 (0.00000000000000000000677626357803380666611097795246328125), 0.000000000000000000084703294725422583326387224405791015625 (0.000000000000000000003388131789016903333055488976231640625), 0.000000000000000000042351647362711291663193612202895578125 (0.0000000000000000000016940658945084516665277444881158203125), 0.0000000000000000000211758236813556458315968061014478828125 (0.00000000000000000000084703294725422583326387224405791015625), 0.00000000000000000001058791184067777291631940305072394140625 (0.00000000000000000000042351647362711291663193612202895578125), 0.0000000000000000000052939559203388864581570152503619707265625 (0.000000000000000000000211758236813556458315968061014478828125), 0.0000000000000000000026469779601694432290785076251809853125 (0.0000000000000000000001058791184067777291631940305072394140625), 0.00000000000000000000132348898008472161453925381259049265625 (0.000000000000000000000052939559203388864581570152503619707265625), 0.000000000000000000000661744490042360807271961906295246328125 (0.000000000000000000000026469779601694432290785076251809853125), 0.0000000000000000000003308722450211804036359809531476231640625 (0.00000000000000000000001323488980042360807271961906295246328125), 0.00000000000000000000016543612251059020181799047657381158203125 (0.00000000000000000000000661744490042360807271961906295246328125), 0.00000000000000000000008271806125529510090899523828695578125 (0.000000000000000000000003308722450211804036359809531476231640625), 0.000000000000000000000041359030627647550454497619143828125 (0.0000000000000000000000016543612251059020181799047657381158203125), 0.0000000000000000000000206795153138237752272488095719140625 (0.0000000000000000000000008271806125529510090899523828695578125), 0.000000000000000000000010339757656911887613624404785957265625 (0.00000000000000000000000041359030627647550454497619143828125), 0.000000000000000000000005169878828455943806812202392978828125 (0.000000000000000000000000206795153138237752272488095719140625), 0.00000000000000000000000258493941422797190340610119649140625 (0.00000000000000000000000010339757656911887613624404785957265625), 0.00000000000000000000000129246970711398595170305059824578125 (0.00000000000000000000000005169878828455943806812202392978828125), 0.00000000000000000000000064623485355699297585152529912390625 (0.0000000000000000000000000258493941422797190340610119649140625), 0.000000000000000000000000323117426778496487925762649561953125 (0.0000000000000000000000000129246970711398595170305059824578125), 0.0000000000000000000000001615587133892482439628813247809765625 (0.0000000000000000000000000064623485355699297585152529912390625), 0.00000000000000000000000008077935669462412198144066239048828125 (0.00000000000000000000000000323117426778496487925762649561953125), 0.00000000000000000000000004038967834731206099072033119744140625 (0.000000000000000000000000001615587133892482439628813247809765625), 0.0000000000000000000000000201948391736560304953601655987207265625 (0.0000000000000000000000000008077935669462412198144066239048828125), 0.000000000000000000000000010097419586828015247680082798869140625 (0.0000000000000000000000000004038967834731206099072033119744140625), 0.0000000000000000000000000050487097934140076238400413994478828125 (0.000000000000000000000000000201948391736560304953601655987207265625), 0.00000000000000000000000000252435489670700381192002069972394140625 (0.00000000000000000000000000010097419586828015247680082798869140625), 0.00000000000000000000000000126217744835350190596001034987207265625 (0.000000000000000000000000000050487097934140076238400413994478828125), 0.000000000000000000000000000631088724176750095298000524987207265625 (0.0000000000000000000000000000252435489670700381192002069972394140625), 0.000000000000000000000000000315544362088375047649000264987207265625 (0.0000000000000000000000000000126217744835350190596001034987207265625), 0.00000000000000000000000000015777218104418752382450013249381158203125 (0.00000000000000000000000000000631088724176750095298000524987207265625), 0.00000000000000000000000000007888609052209376191225000662469140625 (0.00000000000000000000000000000315544362088375047649000264987207265625), 0.00000000000000000000000000003944304526104688095612500331234578125 (0.0000000000000000000000000000015777218104418752382450013249381158203125), 0.0000000000000000000000000000197215226305234404780625016561719140625 (0.0000000000000000000000000000007888609052209376191225000662469140625), 0.0000000000000000000000000000098607613152617220239012508280957265625 (0.0000000000000000000000000000003944304526104688095612500331234578125), 0.000000000000000000000000000004930380657630861011950625414381158203125 (0.000000000000000000000000000000197215226305234404780625016561719140625), 0.00000000000000000000000000000246519032881543050597531220719140625 (0.000000000000000000000000000000098607613152617220239012508280957265625), 0.0000000000000000000000000000012325951644077152529876561035957265625 (0.00000000000000000000000000000004930380657630861011950625414381158203125), 0.0000000000000000000000000000006162975822038576264938280517978828125 (0.0000000000000000000000000000000246519032881543050597531220719140625), 0.0000000000000000000000000000003081487911019288132469140258987207265625 (0.000000000000000000000000000000012325951644077152529876561035957265625), 0.000000000000000000000000000000154074395550964406734572012949381158203125 (0.000000000000000000000000000000006162975822038576264938280517978828125), 0.00000000000000000000000000000007703719777548220336728600647469140625 (0.000000000000000000000000000000003081487911019288132469140258987207265625), 0.00000000000000000000000000000003851859888774110168364300323734578125 (0.00000000000000000000000000000000154074395550964406734572012949381158203125), 0.0000000000000000000000000000000192592994438705505418215016186957265625 (0.0000000000000000000000000000000007703719777548220336728600647469140625), 0.00000000000000000000000000000000962964972193527527091075080934578125 (0.0000000000000000000000000000000003851859888774110168364300323734578125), 0.0000000000000000000000000000000048148248609676376354553754046728828125 (0.000000000000000000000000000000000192592994438705505418215016186957265625), 0.0000000000000000000000000000000024074124304838188177276877023364381158203125 (0.0000000000000000000000000000000000962964972193527527091075080934578125), 0.000000000000000000000000000000001203706215241909408863843851168219140625 (0.000000000000000000000000000000000048148248609676376354553754046728828125), 0.0000000000000000000000000000000006018531076209547044319219255841158203125 (0.000000000000000000000000000000000024074124304838188177276877023364381158203125), 0.00000000000000000000000000000000030092655381047735221596096279207265625 (0.00000000000000000000000000000000001203706215241909408863843851168219140625), 0.00000000000000000000000000000000015046327690523867610798048139603678125 (0.000000000000000000000000000000000006018531076209547044319219255841158203125), 0.000000000000000000000000000000000075231638452619338053990240698019140625 (0.0000000000000000000000000000000000030092655381047735221596096279207265625), 0.00000000000000000000000000000000003761581922630966902699512034900957265625 (0.0000000000000000000000000000000000015046327690523867610798048139603678125), 0.0000000000000000000000000000000000188079096131548345134